

**Cyclone Dust Collector**  
Operating Instructions



**Producer:**

Laguna Tools Inc  
744 Refuge Way, Suite 200  
Grand Prairie, Texas 75050  
USA  
Phone: +1 800-234-1976  
Website: [www.lagunatools.com](http://www.lagunatools.com)

**Distributor:**

IGM nástroje a stroje s.r.o.  
Ke Kopanině 560, 252 67, Tuchoměřice  
Czech Republic, EU  
Phone: +420 220 950 910  
E-mail: [sales@igmttools.com](mailto:sales@igmttools.com)  
Website: [www.igmttools.com](http://www.igmttools.com)





## EC DECLARATION OF CONFORMITY

According to the following EC Directives  
- Machinery Directive : 2006/42/EC



The undersigned, Stephen Stoppenbrink, representing Laguna Tools Inc.  
744 Refuge Way, Suite 200, Grand Prairie, Texas 75050 USA, manufacturer, declares that  
the machine described hereafter :

### **DUST COLLECTOR**

#### **MODEL:**

AFLUX12 (230V/50Hz)  
BFLUX1 (230V/50Hz)  
CFLUX3 (415V/50Hz)  
PFLUX3 (415V/50Hz)  
CFLUX1 (230V/50HZ)  
PFLUX1 (230V/50HZ)

Provided that it is used and maintained in accordance with the generally accepted codes of good practice and the recommendations of the instructions manual, meets the essential safety and health requirements of the Machinery Directive.

The person who compile technical file established within the EU:

Name: IGM nastroje a stroje s.r.o.

Address: Ke Kopanine 560, Tuchomerice , CZ-252 67

Tel.: +420 220 950 910

Email: [sales@igmtools.com](mailto:sales@igmtools.com)

The TCF (No. SF-2018001-A1 / SF-2018002-A1) is archived in CEPROM S.A. located in Str.  
Fântânele, nr.FN (Platforma Industrială), 440240 Satu Mare, Romania

For the most specific risks of this machine, safety and compliance with the essential requirements of the Directive has been based on elements of:

- EN ISO 12100:2010 / Safety of machinery — General principles for design — Risk assessment and risk reduction (ISO 12100:2010)
- EN 60204-1: 2006+A1:2009+AC:2010 / Safety of machinery - Electrical equipment of machines- Part 1: General requirements- Industrial electrical device.

Date: August 04, 2022

Authorized Signature: 

Position: Chief Executive Officer

Place: Laguna Tools Inc.  
744 Refuge Way, Suite 200, Grand Prairie, Texas 75050,  
USA

# EN - English

## Operating Instructions (translation of the original instructions)

Dear Woodworker,

Thank you for your purchase and welcome to the Laguna Tools group of discerning woodworkers. We understand that you have a choice of where to purchase your machines and appreciate the confidence you have in the Laguna Tools brand. Every machine manufactured by Laguna Tools has been carefully designed and well thought through from a woodworker's perspective. Through hands-on experience, Laguna Tools is constantly working hard to make innovative, precision products. Products that inspire you to create works of art, are a joy to run and work on, and encourage your performance.

## Contents

### 1. Declaration of conformity

1.1 Warranty - 2

### 2. CFlux3 Specifications

- 3

### 3. General Safety Rules and Instructions

3.1 Important Safety Instructions - 3  
3.2 General Safety Rules - 4  
3.3 Additional Safety Instructions - 4  
3.4 Motor Specifications - 5  
3.5 Grounding Instructions - 5

### 4. Parts Description

4.1 Functions - 5

### 5. Assembly

5.1 Unpacking - 6  
5.2 General Tool Assembling - 6

### 6. Maintenance

- 11

### 7. Troubleshooting guide

- 12

### 8. Power Connections & Wiring Diagrams

- 13

### 9. Parts Breakdown / Exploded Views

9.1 Section A - 15  
9.2 Section B - 16  
9.3 Section C - 17  
9.4 Section D - 17

### 10. Parts List

- 18

Weight 146 kg  
Shipping Weight 176 kg

Filter  
Filtering Area: 9,5 m2  
Cartridge Filter diameter 400 mm x height 900 mm  
Filtration Size 1 Micron, 99.7 %  
Drum Collection Bag Layflat Size 960 x 1200 mm  
Filter Collection Bag Layflat Size 660 x 620 mm

### 3. General Safety Rules and Instructions

#### 3.1 Important Safety Instructions

Read and understand all warnings and operating instructions before using this equipment. Failure to follow all instructions listed below, may result in electric shock, fire, and/or serious personal injury or property damage.

Woodworking can be dangerous if safe and proper operating procedures are not followed. As with all machinery, there are certain hazards involved with the operation of the product. Using the machine with respect and caution will considerably lessen the possibility of personal injury. However, if normal safety precautions are overlooked or ignored, personal injury to the operator may result. Safety equipment such as guards, push sticks, hold-downs, feather boards, goggles, dust masks and hearing protection can reduce your potential for injury. But even the best guard won't make up for poor judgment, carelessness or inattention. Always use common sense and exercise caution in the workshop. If a procedure feels dangerous, don't try it. Figure out an alternative procedure that feels safer. REMEMBER: Your personal safety is your responsibility.

This machine was designed for certain applications only. We strongly recommend that this machine not be modified and/or used for any application other than that for which it was designed. If you have any questions relative to a particular application, do not use the machine until you have first contacted the manufacturer to determine if it can or should be performed on the product.

If you have any questions relative to its application do not use the product until you have contacted the manufacturer and we have advised you.

When using an electrical appliance, basic precautions should always be followed, including the following:

#### READ ALL INSTRUCTIONS BEFORE USING (THIS APPLIANCE)

To reduce the risk of fire, electric shock, or injury:

- Do not leave appliance when plugged in. Unplug from outlet when not in use and before servicing.
- Do not use outdoors or on wet surfaces.
- Do not allow to be used as a toy. Close attention is necessary when used by or near children.
- Use only as described in this manual. Use only manufacturer's recommended attachments.
- Do not use with damaged cord or plug. If appliance is not working as it should, has been dropped, damaged, left outdoors, or dropped into water, return it to a service centre.
- Do not pull or carry by cord, use cord as a handle, close a door on cord, or pull cord around sharp edges or corners. Do not run appliance over cord. Keep cord away from heated surfaces.
- Do not unplug by pulling on cord. To unplug, grasp the plug, not the cord.
- Do not handle plug or appliance with wet hands.

### 1. Declaration of conformity

We declare that this product is in compliance with the directive and the standard mentioned on the previous page of this manual.

#### 1.1 Warranty

IGM Tools & Machinery strives to always deliver high-quality machinery. The warranty is governed by the valid terms and conditions of IGM Tools & Machinery available at [www.igmttools.com](http://www.igmttools.com).

### 2. Specifications

Motor 2200 W (3Hp)  
Power 400V / 50Hz / 3PH  
Recommended Breaker 20 Amps (Type D)  
Airflow (traditional method) 3831 m3/hour (2253 CFM)  
Airflow (realistic method) 2209 m3/hour (1299 CFM)  
Max. Static Pressure 285 mm in water  
Fan Diameter 390 mm  
Inlet Diameter 1x 200 mm or 3 x 100 mm  
Switch High frequency remote control switch  
Noise Level 82 dB(A) @ 3 m  
Drum Collection Capacity 174 l, octagonal drum  
Packing Size (WxDxH) 1260 x 770 x 1250 mm

- Do not put any object into openings. Do not use with any opening blocked; keep free of dust, lint, hair, and anything that may reduce air flow.
- Keep hair, loose clothing, fingers, and all parts of body away from openings and moving parts.
- Turn off all controls before unplugging.
- Use extra care when cleaning on stairs.
- Do not use to pick up flammable or combustible liquids, such as gasoline, or use in areas where they may be present.
- Connect to a properly grounded outlet only. See Grounding Instructions

#### SAVE THESE INSTRUCTIONS

- Read and understand the warnings posted on the machine and in this manual. Failure to comply with all of these warnings may cause serious injury.
  - Replace the warning labels if they become obscured or removed.
  - This 3HP Portable Cyclone Dust Collector is designed and intended for use by properly trained and experienced personnel only. If you are not familiar with the proper and safe operation of this type of dust collector, do not use until proper training and knowledge have been obtained.
  - Do not use this machine for other than its intended use. If used for other purposes, LAGUNA TOOLS INC., disclaims any real or implied warranty and holds itself harmless from any injury that may result from that use.
  - Always wear approved safety glasses/face shields while using this machine.
  - Before operating this dust collector, remove tie, rings, watches and other jewelry, and roll sleeves up past the elbows. Remove all loose clothing and confine long hair. Non-slip footwear or anti-skid floor strips are recommended. Do not wear gloves.
  - Wear ear protectors (plugs or muffs) during extended periods of operation.
  - Some dust created by power sanding, sawing, grinding, drilling and other construction activities contain chemicals known to cause cancer, birth defects or other reproductive harm. Some examples of these chemicals are:
    - Lead from lead based paint.
    - Crystalline silica from bricks, cement and masonry products.
    - Arsenic and chromium from chemically treated lumber.
- Your risk of exposure varies, depending on how often you do this type of work. To reduce your exposure to these chemicals, work in a well-ventilated area and work with approved safety equipment, such as face or dust masks that are specifically designed to filter out microscopic particles.
- Do not operate this machine while tired or under the influence of drugs, alcohol or any medication.
  - Make certain the switch is in the OFF position before connecting the machine to the power source.
  - Make certain the machine is properly grounded.
  - Make all machine adjustments or maintenance with the machine unplugged from the power source.
  - Form a habit of checking to see that all extra equipment such as adjusting keys, wrenches, scrap, stock, and cleaning rags are removed away from the machine before turning on.
  - Keep safety guards in place at all times when the machine is in use. If removed for maintenance purposes, use extreme caution and replace the guards immediately when maintenance is complete.
  - Make sure the dust collector is on a flat even surface and the wheels locked in place before use.
  - Check damaged parts. Before further use of the machine, a guard or other part that is damaged should be carefully checked to determine that it will operate properly and perform its intended function. Check for alignment of moving parts, binding of moving parts, breakage of parts, mounting and any other conditions that may affect its operation. A guard or other part that is damaged should be properly repaired or replaced.

- Provide for adequate space surrounding work area and non-glare, overhead lighting.
- Keep the floor around the machine clean and free of scrap material, oil and grease.
- Keep visitors a safe distance from the work area. Keep children away.
- Make your workshop child proof with padlocks, master switches or by removing starter keys.
- Give your work undivided attention. Looking around, carrying on a conversation and "horse-play" are careless acts that can result in serious injury.
- Maintain a balanced stance at all times so that you do not fall or lean against the dust collector. Do not overreach or use excessive force to perform any machine operation.
- Use the right tool at the correct speed and feed rate. Do not force a tool or attachment to do a job for which it was not designed. The right tool will do the job better and safer.
- Use recommended accessories; improper accessories may be hazardous.
- Maintain machinery with care. Follow instructions for lubricating and changing accessories.
- Turn off the machine before cleaning. Use a brush or compressed air to remove dust or debris — do not use your hands.
- Do not stand on the machine. Serious injury could occur if the machine tips over.
- Never leave the machine running unattended. Turn the power off and do not leave the machine until it comes to a complete stop.

### 3.2 General safety rules

**WARNING: FAILURE TO FOLLOW THESE RULES MAY RESULT IN SERIOUS PERSONAL INJURY.**

**CHECK DAMAGED PARTS.** Before further use of the unit, properly repair or replace any part that is damaged.

**FOR YOUR OWN SAFETY, READ AND UNDERSTAND THE INSTRUCTION MANUAL BEFORE OPERATING THE MACHINE.** Learn the unit's application and limitations as well as the specific hazards peculiar to it.

**KEEP WORK AREA CLEAN.** Cluttered areas and benches invite accidents.

**DON'T USE IN DANGEROUS ENVIRONMENT.** Don't use this unit in damp or wet locations, or expose it to rain. Keep work area well-lighted.

**KEEP CHILDREN AND VISITORS AWAY.** All children and visitors should be kept a safe distance from work area.

**DISCONNECT UNIT** before servicing.

**CHECK DAMAGED PARTS.** Before further use of the unit, properly repair or replace any part that is damaged.

**FAILURE TO FOLLOW THESE RULES MAY RESULT IN SERIOUS INJURY.**

### 3.3 Additional Safety Instructions

#### Additional safety for dust collectors

**Intended use.** This dust collector is only intended for collecting wood dust and chips from woodworking machines. Do not use this dust collector to collect metal, dirt, pebbles, drywall, asbestos, lead paint, silica, liquids, aerosols, or any flammable, combustible, or hazardous materials.

**Hazardous dust.** Dust created while using machinery may cause cancer, birth defects, or long-term respiratory damage. Be aware of dust hazards associated with each work piece material, and always wear a NIOSH-approved respirator to reduce your risk.

**Dust allergies.** Dust from certain woods may cause an allergic reaction in

people and animals. Make sure you know what type of wood dust you will be exposed to in case there is a possibility of an allergic reaction.

**Wear respirator.** Fine dust that is too small to be caught in the filter will be blown into the ambient air during operation. Always wear a NIOSH-approved respirator during operation and for a short time after to reduce your risk of permanent respiratory damage.

**Emptying dust.** When emptying dust from the collection container, wear a respirator and safety glasses. Empty dust away from ignition sources and into an approved container.

**Disconnecting power supply.** Turn the switch off, disconnect the dust collector from the power supply, and allow the impeller to come to a complete stop before leaving the machine unattended or doing any service, cleaning, maintenance, or adjustments.

**Suspended dust particles and ignition sources.** Do not operate the dust collector in areas where explosion risks are high. Areas of high risk include, but are not limited to, areas near pilot lights, open flames, or other ignition sources.

**Fire suppression.** Only operate the dust collector in locations that contain a fire suppression system or have a fire extinguisher nearby.

**Impeller hazards.** Do not place your hands or tools near the open inlet during operation for any reason. The powerful suction could easily cause accidental contact with the impeller, which will cause serious personal injury or damage to the machine. Always keep small animals and children away from open dust collection inlets.

**Avoiding sparks.** Do not allow steel or rocks to strike the impeller—this may produce sparks. Sparks can smolder in wood dust for a long time before a fire is detected. If you accidentally cut into wood containing tramp metal (nails, staples, spikes, etc.), immediately turn off the dust collector, disconnect it from power, and wait for the impeller to stop—then empty the collection container into an approved airtight metal container.

**Operating location.** To reduce respiratory exposure to fine dust, locate permanently installed dust collectors away from the working area, or in another room that is equipped with a smoke detector. Do not operate the dust collector in rainy or wet locations—exposure to water may create a shock hazard or decrease the life of the machine.

**Static electricity.** Plastic dust lines generate high amounts of static electricity as dust chips pass through them. Although rare, sparks caused by static electricity can cause explosions or fire. To reduce this risk, make sure all dust lines are thoroughly grounded by using a grounding wire.

**Regular cleaning.** Regularly check/empty the collection bags or drum to avoid the buildup of fine dust that can increase the risk of fire. Make sure to regularly clean the surrounding area where the machine is operated—excessive dust buildup on overhead lights, heaters, electrical panels, or other heat sources will increase the risk of fire.

Warning: If precautions are not heeded, it may result in minor injury and/or possible machine damage.

Warning: If precautions are not heeded, it may result in serious injury or possibly even death.

#### SAVE THESE INSTRUCTIONS.

Refer to them often and use them to instruct others.

### 3.4 Motor Specifications

Your machine is wired for 400 volts, 50 HZ alternating current. Before connecting the machine to the power source, make sure the switch is in the "OFF" position.

### 3.5 Grounding Instructions

**DANGER: THIS MACHINE MUST BE GROUNDED WHILE IN USE TO PROTECT THE OPERATOR FROM ELECTRIC SHOCK.**

1. This appliance must be connected to a grounded metal, permanent wiring system; or an equipment-grounding conductor must be run with the circuit conductors and connected to the equipment-grounding terminal or lead on the appliance.

The installer, such as a qualified electrician, cut (or bend over) and insulate the grounding conductor from a field wiring supply cable.

In the event of certain types of malfunctions or breakdowns, grounding

provides a path of least resistance for electric current—in order to reduce the risk of electric shock.

Improper connection of the equipment-grounding wire can result in a risk of electric shock. The wire with green insulation (with or without yellow stripes) is the equipment-grounding wire. If repair or replacement of the power cord or plug is necessary, do not connect the equipment-grounding wire to a live (current carrying) terminal. Check with a qualified electrician or service personnel if you do not understand these grounding requirements, or if you are in doubt about whether the tool is properly grounded. If you ever notice that a cord or plug is damaged or worn, disconnect it from power, and immediately replace it with a new one.

### Full Load Amperage

Amp draw at 230V (prewired) 17 A

### Electrical Circuit Requirements

You should use a separate electrical circuit for the Laguna CFlux. The circuit should be protected by a 16A circuit breaker with a tripping characteristic C (16/3 / C). The power cable of the machine is factory fitted with 400V industrial plug. The machine must be connected to an appropriate industrial socket or the machine can be connected to a terminal board and the wiring corresponding to the recommended fuse.

**ATTENTION! WIRING MAY BE CARRIED OUT BY A QUALIFIED ELECTRICIAN ONLY.**

Recommended circuit breaker: 16A (16/3/C), tripping characteristic C.

**WARNING: MAKE SURE THE SOCKET IS EARTHED. IF YOU ARE NOT SURE, HAVE THE SOCKET CHECKED BY A QUALIFIED ELECTRICIAN.**

## 4. Parts Description

### 4.1 Functional Description

#### High frequency remote control switch



#### Hand held remote controller



### PROGRAMMING THE REMOTE CONTROL

1. Ensure the machine is ON before programming the remote control.
2. Press the BLACK set button on the bottom of the remote switch until you hear two beeps.
3. Press the Remote set button on your hand held controller simultaneously with the BLACK button until you hear three beeps to complete the set up.

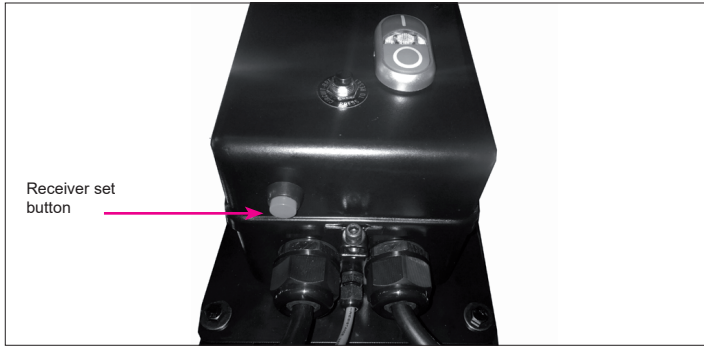

### Tools Required

10 mm wrench / 12 mm wrench / 14 mm wrench  
Phillips screwdriver. 4 mm hex wrench / 5 mm hex wrench

To assemble your dust cyclone, follow these steps:  
For your own safety, do not connect the machine to the power source until the machine is completely assembled. Please also make sure that you read and understand the entire instruction manual.

### ASSEMBLY TIME ESTIMATE 4-5 hours

Step 1: Turn the unit upside down. Make sure you use a cushion under the canister top side to even out the unit to the same height as the motor. Do not have the unit lopsided. Remove the base (G) which has been fastened to the (3) top upright supports (E).

## 5. Assembly

### 5.1 Unpacking

Your 3HP Mobile Dust Cyclone comes packed in a single box. Before attempting to assemble this machine, follow these directions for unpacking:

- Carefully cut the banding straps and remove them from the box.
- Cut along the tape line at the top of the box.
- Remove all parts from the top of the styrofoam and set aside.
- Remove the styrofoam packing material from the top of the machine.
- Carefully take out the machine components from the box and set aside.
- Using the diagram below, ensure that all parts are present and in good condition.



### Description

- A. Motor
- B. Switch and remote controller
- C. Dust chute
- D. Top upright supports (3)
- E. Canister 1 Micron
- F. Base frame
- G. Rotation shaft
- H. Rotation paddle (2)
- I. Crossbar
- J. Octagon drum lid
- K. Cyclone funnel
- L. Cyclone barrel
- M. Intake cylinder
- N. Canister cover plate
- O. Octagon front and back panel
- P. Octagon drum foot pedal
- Q. Inlet adapter
- R. Lower upright supports (3)
- S. Drum insert
- T. Upright support reinforcement plate (3)
- U. Foot pedal bar (left and right)
- V. Foot pedal assembly fittings
- V1. Lower triangular support plate (2)
- V2. Foot pedal bar support (2)
- V3. Lower support plate (2)
- W. Hardware box
- X. Operating and Parts Manual
- Y. Dust bags

Report any missing or damaged parts to your dealer or distributor. Prior to tool assembly and use, read this manual thoroughly to familiarize yourself with proper assembly, maintenance and safety procedures.

### 5.2 General Tool Assembly

**This step requires two adults.** This 3HP Mobile Dust Cyclone is heavy, be careful when lifting and handling it! Failure to comply may cause serious injury and/or damage to the machine and/or property!

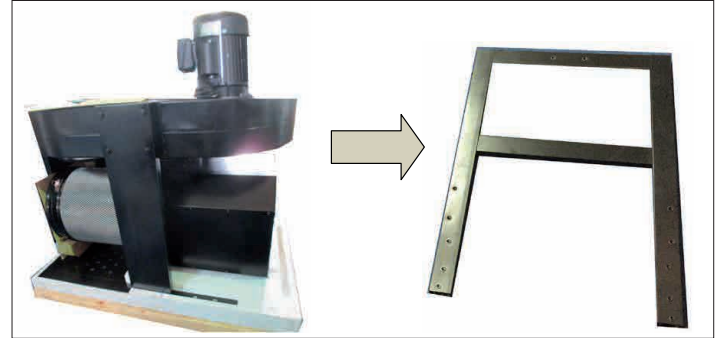

Step 2: Secure the (4) 76 mm wheels to the underside of the base (F) using (16) 8 mm\*19 mm hex bolts and (16) 8 mm\*OD18\*2T flat washers.

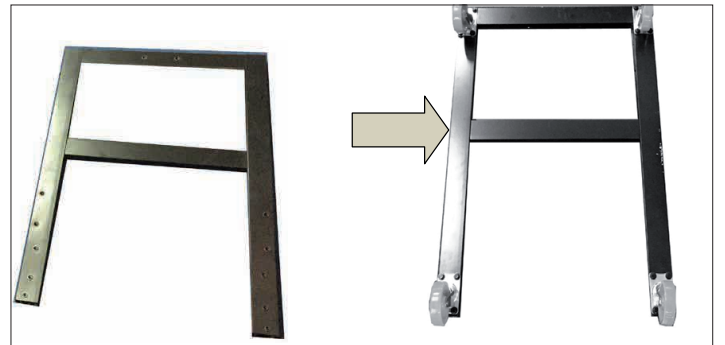

Step 3: Turn the base (F) around with it standing on the 4 red wheels and secure the three lower upright support panels (P) using hex bolts (6) 9 mm\*19 mm and flat washers (6) 9 mm\*OD23\*2T. Each lower upright support panels (P) numbered for its specific location. A – shown with one dot is located on the canister side. B – shown with two dots with extension on left is located on the front side. C – shown with two dots with extension on right is located on opposite end.

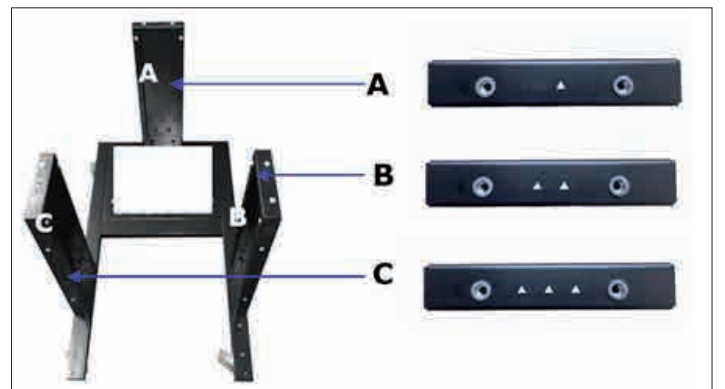

Step 4: Install the foam tape to the upper and lower rims of the three components listed, Cyclone funnel, Cyclone barrel, and Intake cylinder.

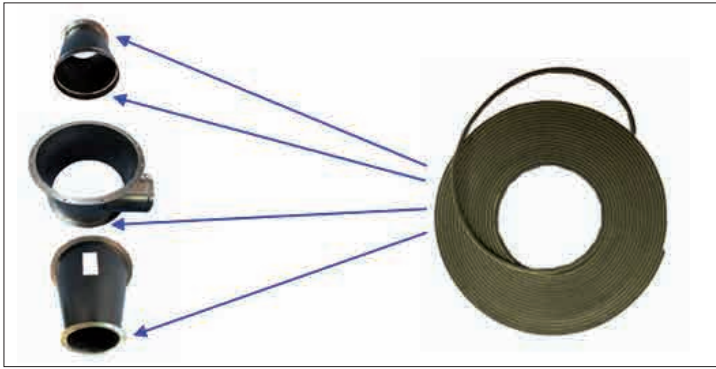

Step 5: Attach the intake cylinder to the dust chute using hex spring bolts (4) 8 mm\*16 mm. Then, attach the cyclone barrel onto the dust chute using hex bolts (12) 8 mm\*19 mm and flat washers (12) 8 mm\*OD18\*2T. Followed by attaching the cyclone funnel to the barrel using hex bolts (12) 8 mm\*19 mm, flat washers (24) 8 mm\*OD18\*2T and hex nuts (12) 8 mm.

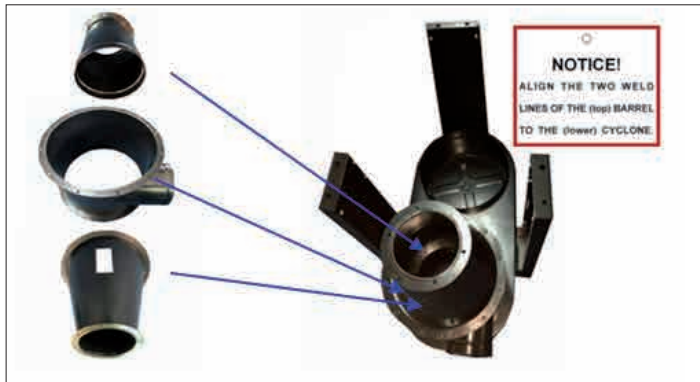

Step 6: Secure the base with (3) lower upright support panels to the unit using hex bolts (6) 8 mm\*19 mm and flat washers (6) 8 mm\*OD18\*2T.



Step 7: Secure the 3 (T) upright support reinforcement plates using hex bolts (12) 8 mm\*19 mm and flat washers (12) 8 mm\*OD18\*2T.

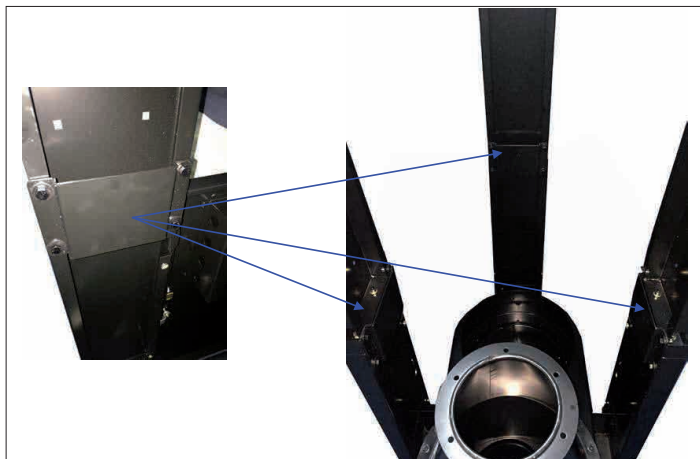

Step 8: With the help of another person, lift the unit up carefully to the right side up with the motor on top and the wheels at the bottom.



Step 9: Secure the lower triangular support plate to the base using (2) 5/16" x 3/4" hex bolts and (2) 5/16" x 18 x 2 flat washers. Follow the same steps for the opposite side.

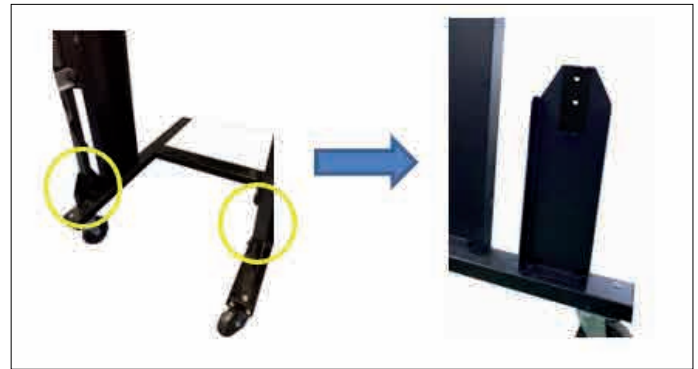

Step 10: Secure the foot pedal support bracket to the lower upright support panel using (2) 5/16" x 1/2" carriage bolts, (2) 5/16" x 18 x 2 flat washers and (2) 5/16" hex nuts. Make sure the armrest of the support bracket is facing up. Follow the same steps for the opposite side.

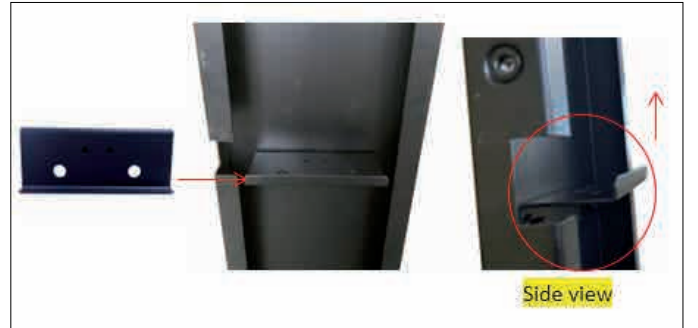

Step 11: Locate the two-foot pedal bars provided. There is a left side and right side. To identify the correct side, look for the protruding nut, circled in red below. It should be facing upwards when you place the bars on the floor.

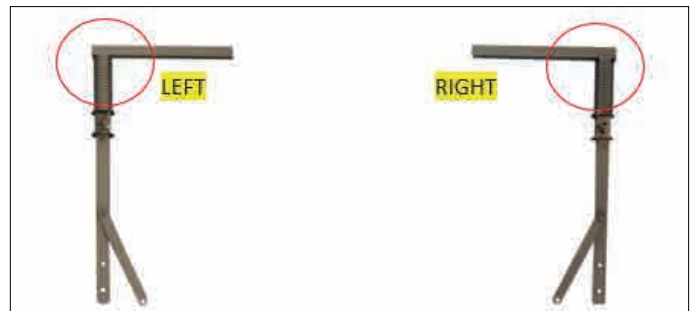

Step 12: Ensure that the foot pedal bar is the correct side and slide the Foot pedal bar into the opening on the lower upright support panel. Follow the same steps for the opposite side.



Step 13: Secure the top end of the foot pedal bar to support bracket using (4) 5/16" x 1-3/4" hex bolts, (8) 5/16" x 18 x 2 flat washers and (4) 5/16" hex nuts. Make sure the foot pedal bar is pushed all the way to the end of the support bracket (indicated by yellow arrows). Follow the same steps for the opposite side.



Step 14: Secure the base of the foot pedal bar to the triangular support plate by holding the lower support plate vertically up against the foot pedal bar and secure the U channel onto the foot pedal bar using (2) 5/16"x1-3/4" hex bolts, (4) 5/16" x 18 x 2 flat washers and (2) 5/16" hex nuts from the inside out. Follow the same steps for the opposite side.



Step 15: Attach the two ends of the Octagon foot pedal to the nut on the foot pedal bar.

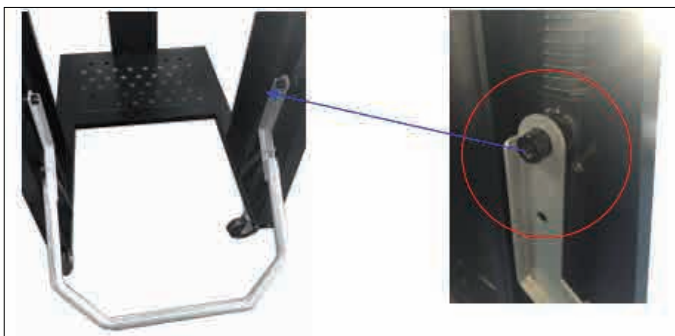

Step 15: Secure the topping to the nut on the foot pedal bar. Follow this step on the opposite side.



Step 17: Secure the topping with (2) M8\*30mm hex bolts.

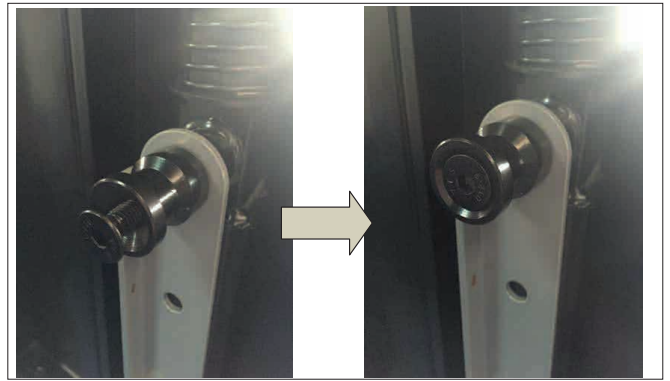

Step 18: Align the bolt hole on the movable supporting brace on the foot peddle bar with the bolt hole on the octagon foot peddle.

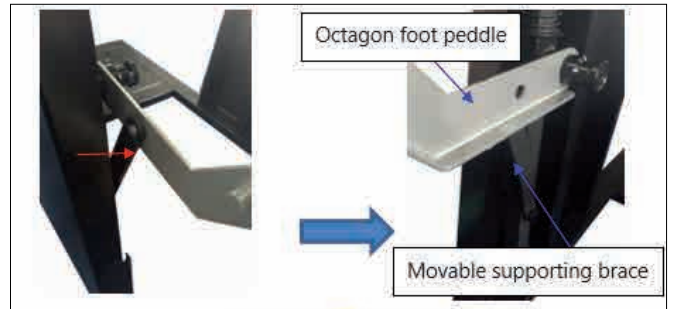

Step 19: Secure the movable supporting brace on the foot pedal bar with the octagon foot pedal using (2) 9 mm\*21 mm. Make sure the bolt head is on the inside of the octagon handle. Adjust the tightness of this bolt accordingly. If this bolt is too tight, the Octagon foot pedal will not work smoothly. When too loose it will not pick up the Octagon drum.

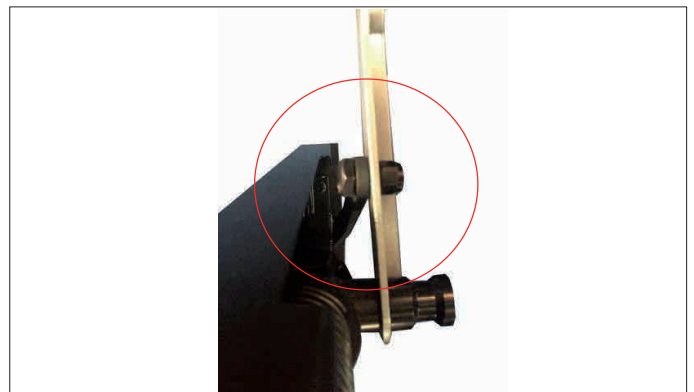

Step 20: Secure the Octagon drum lid to the cyclone funnel using hex bolts (8) 8 mm\*19 mm, flat washers (16) 8 mm\*OD18\*2T and hex nuts (8) 8 mm. Make sure to first attach all the bolts on before tightening the bolts.

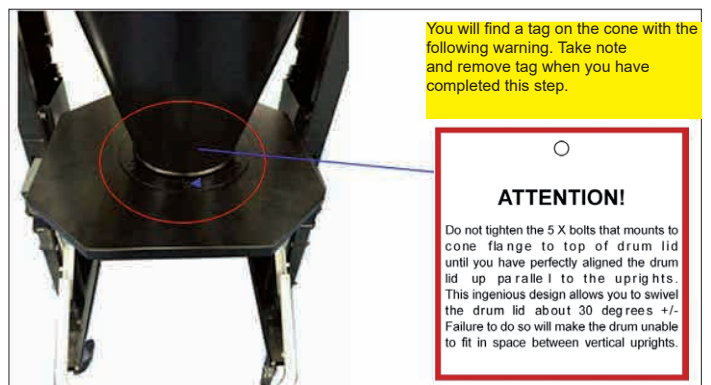

Step 21: Attach the crossbar to the drum lid and tighten using (2) 5/16" x 3/4" hex bolts, (4) 5/16" flat washers and (2) 5/16" hex nuts. It does not matter which position you attach the crossbar.



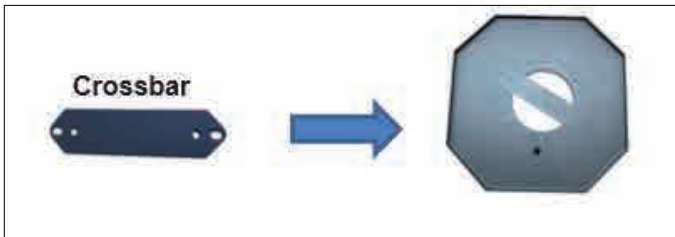

Step 22: Assemble the Octagon drum. Locate the drum base panel (it does not matter which side faces inside) and secure the (4) 3" casters using (16) 5/16" x 3/4" hex bolts, (32) 5/16" flat washers and (16) 5/16" hex nuts.

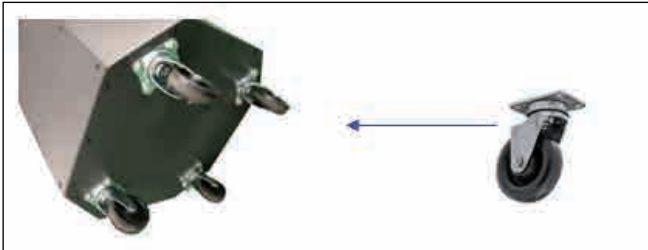

Step 23: Take the Octagon drum front and back panels and assemble using (12) M4 x 12mm sheet metal screws.



Step 24: One the left and right side you will find three bolt holes. Take the matching side plate and secure to the outside of the panel using (6) 1/4" x 1/2" carriage bolts, (6) 1/4" flat washers and (6) 1/4" hex nuts. Insert the head of the carriage bolt from the inside of the drum with the washers and nuts on the outside of the drum.



Step 25: Lay the drum on its side with the handle facing top. With the help of another person, hold the base panel with wheels up against the base of the drum. Using (22) M5 Sheet metal screws to secure tightly. Make sure the head of the truss head Philip screw is on the inside of the drum. Take the plastic bolt end caps to cover all the bolt ends on the inside of the Octagon drum base using (22) plastic end caps. This step is necessary to prevent any injuries caused by the sharp end of the bolts.

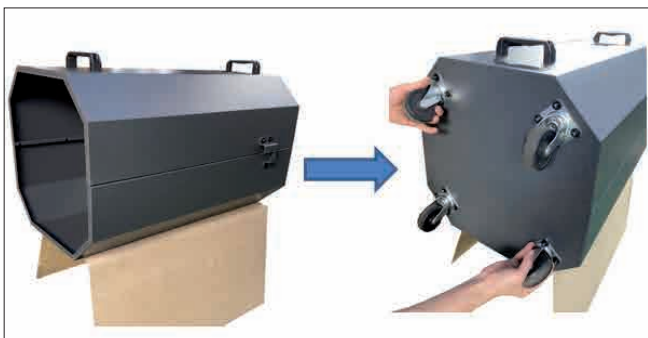

Step 26: Once completing the assembly, apply silicone to the inside of the drum including the base to seal and prevent air leakages and air flow loss.



Step 27: Attach the handles to the top and bottom end on the front panel with the window display using (4) flat head Philip bolts, (4) flat washers 8 mm\*OD23\*2T and hex nuts (4) 8 mm.



Step 28: Attach the rubber gasket to the top inner edges of the Octagon drum. The wider end of the gasket goes up. You will need tin snips to trim any excess rubber gasket after completing the seal.



Step 29: Insert the plastic bag inside the Octagon drum. Open and spread out the plastic bag to the corners and edges.



Step 30: Place the drum insert inside over the plastic bag in the Octagon drum.



Step 31: Lift the foot peddle bar. Align the Octagon drum window to the center point of the drum lid and push the drum in. Lower the foot peddle bar (s) to seal the drum tight for normal machine operation.



Step 32: Make sure when aligning the drum that both the left and right side lift plates are over the topping on the foot peddle bar assembly before lifting the foot peddle bar up. When not aligned, the drum will not be fully sealed and will interfere with the air flow.

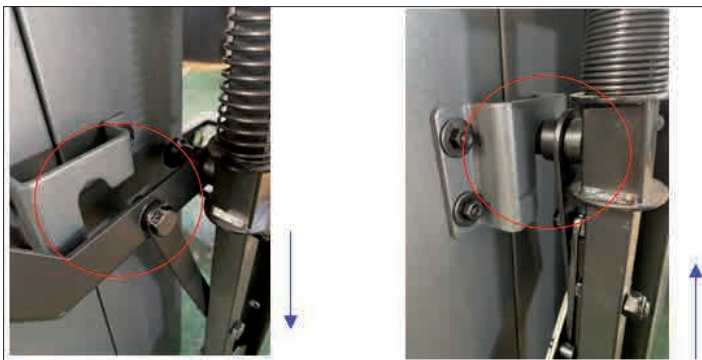

Step 33: Take the switch box, open it by removing the bolt at the bottom of the switch box to mount to the switch base plate using (4) M4 x 6mm flat head bolts.

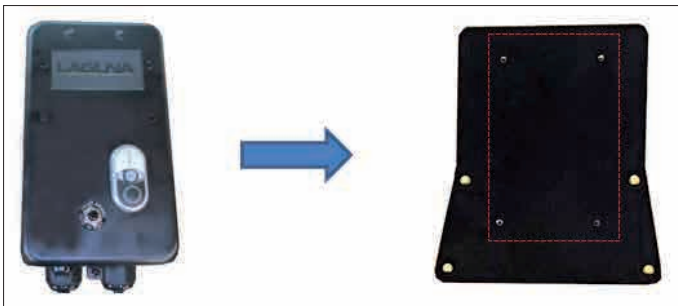

Step 34: Install the Remote Switch Box to the switch plate on the motor using hex bolts (4) 6 mm\*19 mm and flat washers (4) 6 mm\*OD19\*2T.

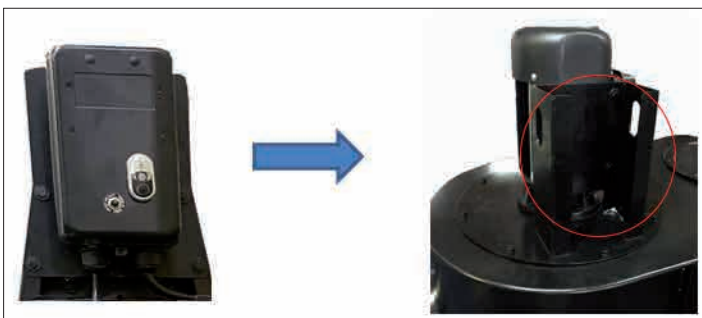

Step 35: Take the paddle and paddle branch and assemble together using hex bolts (4) 6 mm\*16 mm, flat washers (4) 6 mm\*OD19\*1T and nuts (4) 6 mm.

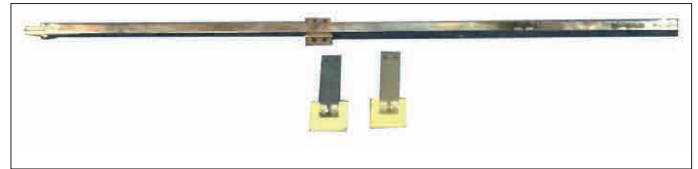

Step 36: Assemble the two paddle and paddle branch assemblies to the rotation shaft using hex bolts (4) 6 mm\*16 mm, flat washers (4) 6 mm\*OD19\*1T and nuts (4) 6 mm.

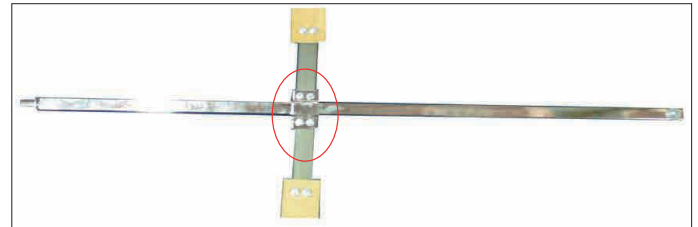

Step 37: Insert the rotation shaft assembly into the canister filter. Slightly bend the paddles to get them into the canister filter.

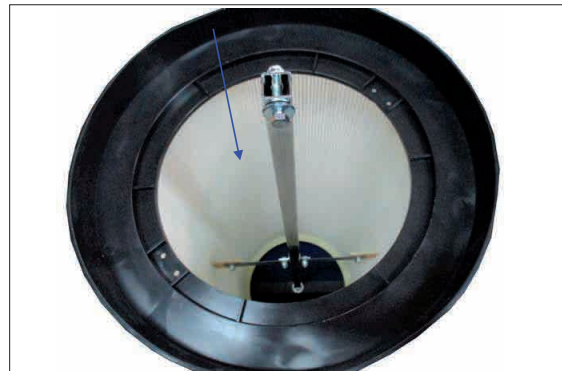

Step 38: Assemble the canister filter to the dust chute. Tighten the band clamp and adjust the tightness accordingly to ensure the canister filter is tightly fitted onto the dust chute.



Step 39: Attach the canister cover plate to the dust chute using (12) 5 mm\*13 sheet metal thread bolts.

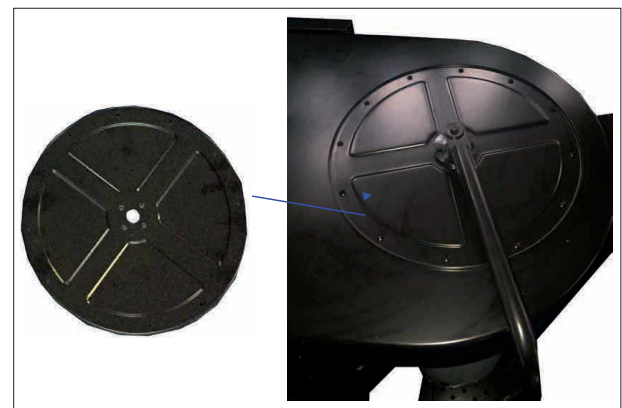

Step 40: From the bottom of the canister filter, push the rotation shaft through the hole in the middle of the canister cover plate.

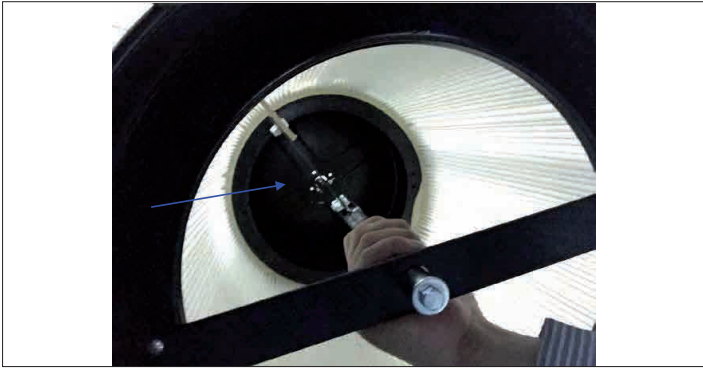

Step 41: While holding the rotation shaft above the hole, insert the bearing onto the shaft. This will fix the rotation shaft in place and you will not need to keep holding it up. Secure the bearing using bolts (4) 6 mm\*19 mm and washers (4) 6 mm\*OD19\*2T.

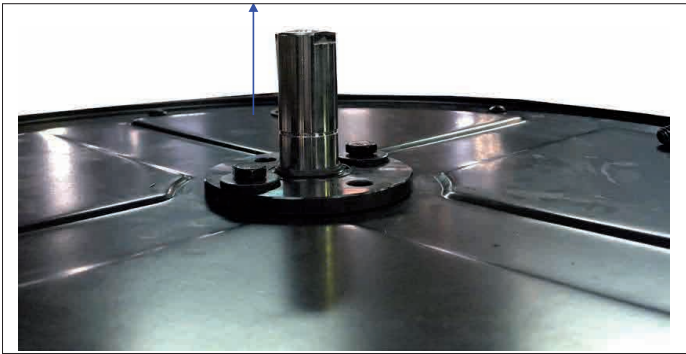

Step 42: Secure and tighten the (1) 8 mm\*19 mm and (1) 8 mm\*OD23\*2T flat washer on the rotation shaft base.

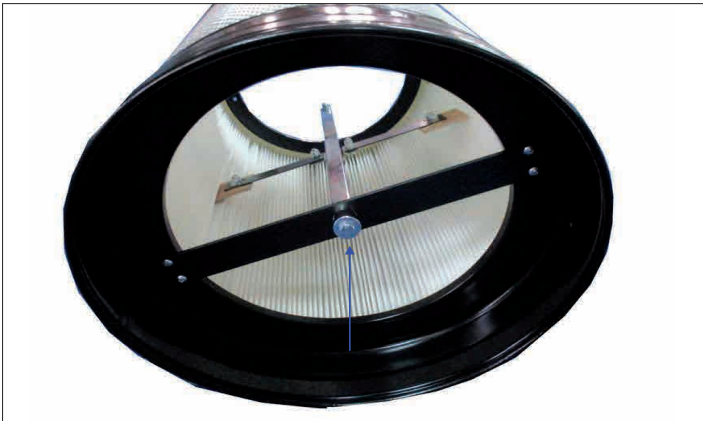

Step 43: Attach and secure the rotation crank to the top of the rotation shaft using a hex bolt (1) 8 mm\*19 mm and a flat washer (1) 8 mm\*OD30\*3T.



Step 44: Install the intake splitter to the intake using (3) M4 x 12mm sheet metal screws. Attach the rubber caps to each 4" port.

All the assembly steps have been completed.



## 6. Maintenance procedures

### CLEANING THE FILTER

To ensure proper operation of this Mobile Dust Cyclone, the HEPA canister filter must have adequate air flow. This means the filter must be regularly maintained by carefully blowing the filter clean using compressed air and an air gun to release built-up particulates trapped between the filter pleats.

For heavy duty users, it is recommended to use compressed air on a regular basis to maintain maximum filtration efficiency and longer life span of the filter.

### Using the Filter Cleaner Crank

The filter cleaner crank knocks dust particulate and small debris from the pleated filter and into the filter bag.

To keep your machine in good working condition, it is recommended that you use the filter cleaner crank to clean the filter after every use.

To clean the filter using the crank simply rotate the crank handle clockwise four or five rotations.

### Using Compressed Air

Disconnect machine from power!

For heavy duty users, it is recommended to use compressed air on a weekly basis to maintain maximum filtration efficiency and longer life span of the filter.

### REMOVING THE CANISTER FILTER

1. Follow the steps 29 to 34 in reverse to remove the canister filter.
2. With the canister filter removed use a compressed air gun to thoroughly clean between the pleats, both inside and outside.

### RE-ASSEMBLING THE CANISTER FILTER AFTER CLEANING

1. With the aid of another person, carefully re-insert the canister filter repeating steps twenty nine to thirty four.

### EMPTYING OR REPLACING THE FILTER BAG

Periodically check the filter bag, if it is more than one third full, it is recommended that you empty it.

**Pozn.:** If the filter bag gets too full, the weight may force it to pull away from the band clamp, exposing the user to potentially harmful particulates.

1. Release the spring-loaded band clamp at the bottom of the filter and remove the filter bag.
2. Empty or replace the filter bag and re-attach using the spring-loaded band clamp.

### EMPTYING THE DRUM

Periodically inspect the contents of the drum and empty as needed. To inspect the contents of the drum:

1. Raise the drum foot peddle bar to lower the drum to the floor.
2. Roll it away from the machine, inspect and empty as needed.

### ROUTINE INSPECTION

It is a good idea to routinely inspect any quality woodworking tool in order to keep it in optimum condition. This includes inspecting all hardware for tightness, ensuring the filter is clean, and cleaning debris and grime from any surfaces and moving parts.

## 7. Troubleshooting guide

<p><b>Machine does not start or a breaker trips.</b></p> <p>Possible Cause</p> <ol style="list-style-type: none"> <li>1. Power supply switched OFF or is faulty.</li> <li>2. Wall fuse/circuit breaker is blown/tripped.</li> <li>3. Faulty remote control.</li> <li>4. Remote receiver is faulty.</li> <li>5. Incorrectly wired motor connection.</li> <li>6. On-board circuit breaker is tripped.</li> <li>7. Wiring is open/has high resistance.</li> <li>8. Faulty power switch.</li> <li>9. Motor is at fault.</li> </ol>	<p>Possible Solution</p> <ol style="list-style-type: none"> <li>1. Ensure power supply is ON and has the correct voltage.</li> <li>2. Ensure adequate circuit size; install inlet restrictor, replace weak breaker.</li> <li>3. Replace batteries; ensure unobstructed line-of-sight and signal range.</li> <li>4. Inspect receiver circuit board; replace if faulty.</li> <li>5. Rewire or call certified service technician or electrician.</li> <li>6. Allow motor to cool, improve ventilation, press reset button.</li> <li>7. Check for broken wires or poor connections, repair as necessary.</li> <li>8. Replace switch.</li> <li>9. Test/repair/replace.</li> </ol>
<p><b>Excessive vibration or noise during operation.</b></p> <p>Possible Cause</p> <ol style="list-style-type: none"> <li>1. Loose component.</li> <li>2. Loose or broken motor mount.</li> <li>3. Motor fan hitting fan cover.</li> <li>4. Bad motor bearings.</li> </ol>	<p>Possible Solution</p> <ol style="list-style-type: none"> <li>1. Inspect and tighten all bolts/nuts.</li> <li>2. Tighten or replace as needed.</li> <li>3. Check fan and cover; replace as needed.</li> <li>4. Rotate shaft manually, check for grinding or loose shaft, replace bearings if needed.</li> </ol>
<p><b>Loud, repetitive noise, or excessive vibration coming from cyclone</b></p> <p>Possible Cause</p> <ol style="list-style-type: none"> <li>1. Machine is on uneven surface.</li> <li>2. Damaged/Unbalanced impeller.</li> <li>3. Loose connections.</li> <li>4. Impeller is loose.</li> <li>5. Motor fan hitting fan cover.</li> </ol>	<p>Possible Solution</p> <ol style="list-style-type: none"> <li>1. Stabilize on a flat surface.</li> <li>2. Inspect impeller for dents, bends, loose fins. Replace if needed.</li> <li>3. Check and re-tighten all fasteners.</li> <li>4. Replace the motor and impeller.</li> <li>5. Check fan and cover; replace as needed.</li> </ol>
<p><b>Dust cyclone does not adequately collect dust or chips; poor performance.</b></p> <p>Possible Cause</p> <ol style="list-style-type: none"> <li>1. Canister end cap is full.</li> <li>2. Filter is dirty.</li> <li>3. Restricted duct line.</li> <li>4. Suction route is too long or has too many sharp bends.</li> <li>5. Wet lumber is clogging ducts.</li> <li>6. Leaks in the duct work or too many open ports.</li> <li>7. Inadequate velocity in the main suction line.</li> <li>8. Wrong size ducting/ports used.</li> </ol>	<p>Possible Solution</p> <ol style="list-style-type: none"> <li>1. Empty canister end cap.</li> <li>2. Clean filter.</li> <li>3. Clean inlet splitter.</li> <li>4. Move machine closer to the point of suction, and rerun ducts to eliminate sharp bends.</li> <li>5. Use lumber with less than 20% moisture content.</li> <li>6. Repair all duct leaks and close any ports not being used.</li> <li>7. Increase velocity by opening 1 or 2 more blast gates to different branch lines.</li> <li>8. Re-size and re-install ducts and fittings.</li> </ol>
<p><b>Sawdust being blown into the air from the dust cyclone.</b></p> <p>Possible Cause</p> <ol style="list-style-type: none"> <li>1. Band clamp or end cap is not secure.</li> <li>2. Loose or damaged seals.</li> </ol>	<p>Possible Solution</p> <ol style="list-style-type: none"> <li>1. Re-install ensuring a tight fit.</li> <li>2. Replace seals and gaskets.</li> </ol>

## 8. POWER CONNECTIONS & WIRING DIAGRAMS

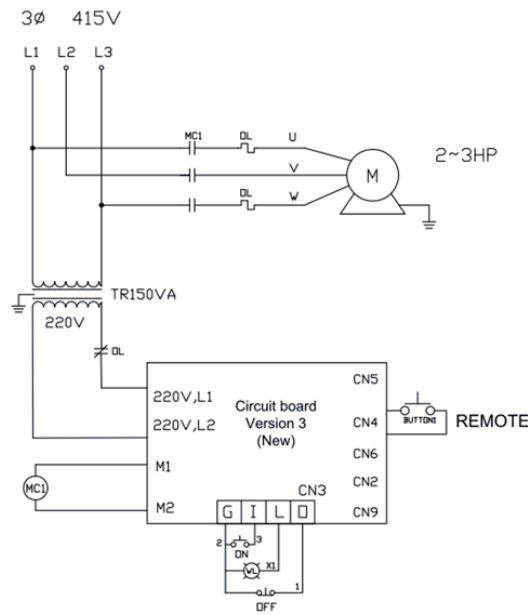

### Power Connections & Wiring

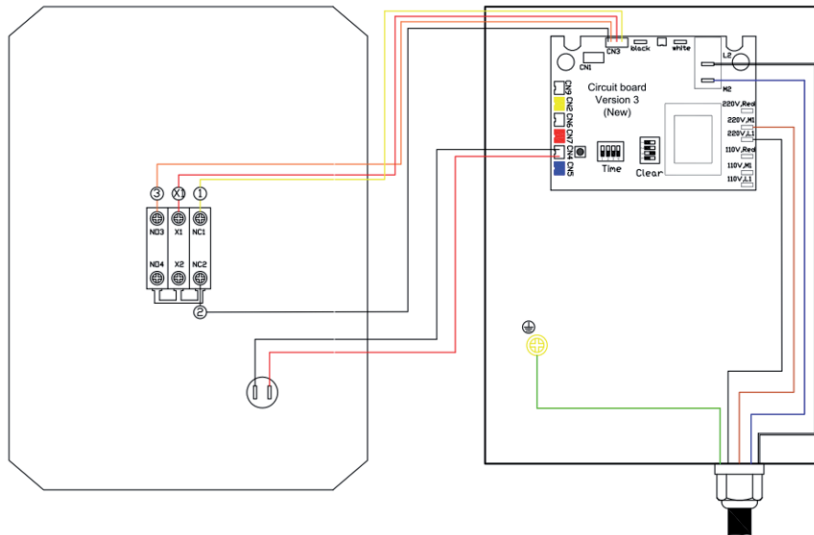

Secondary control box internal wiring

### Internal Wiring

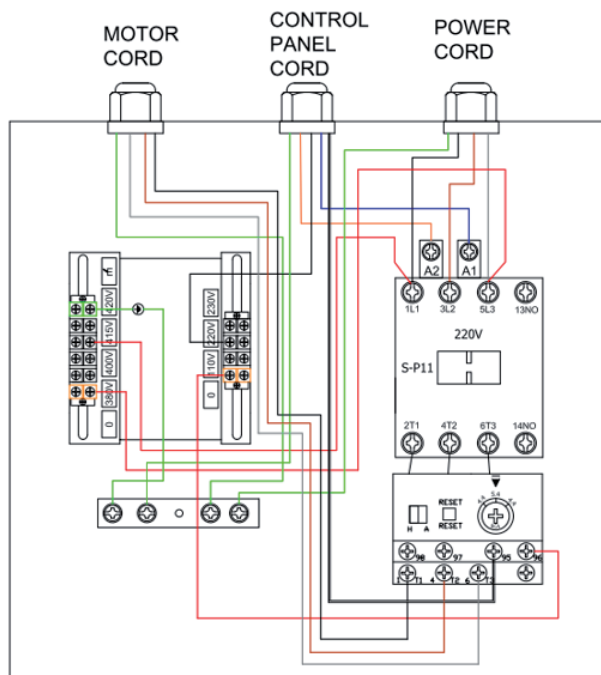

## 9. Parts breakdown / Exploded Views

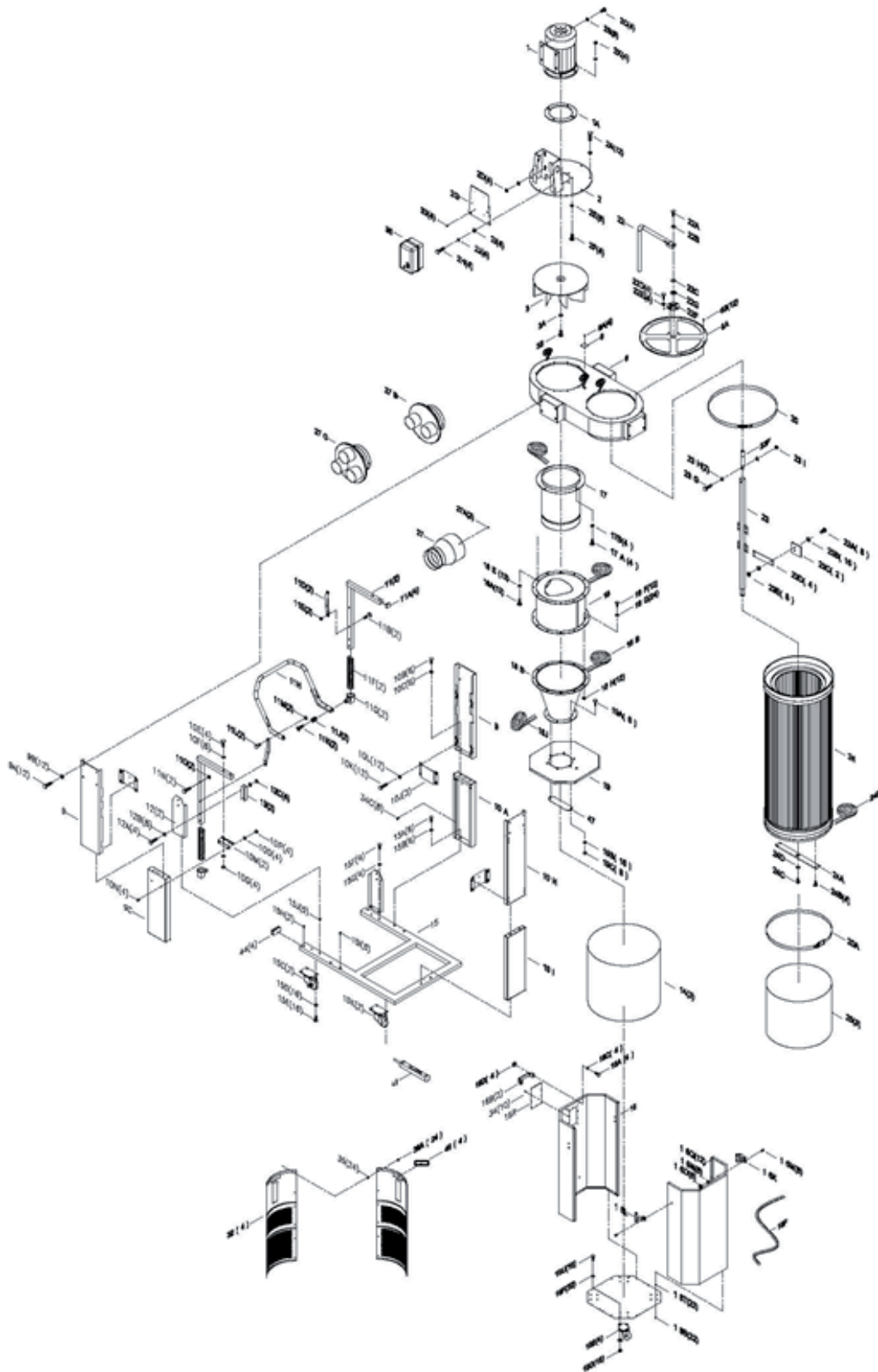

9.1 SECTION A  
(Close up view)

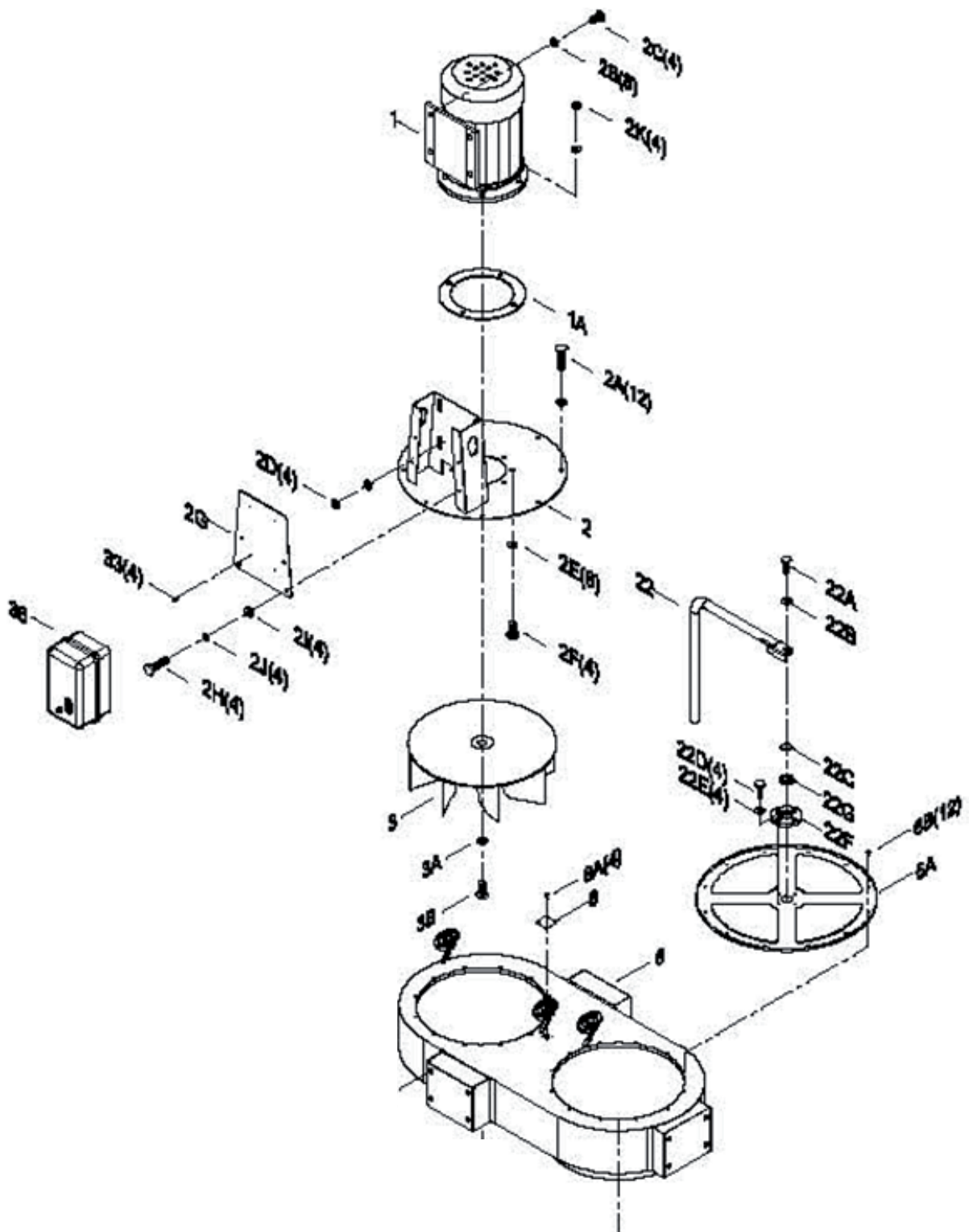

9.2 SECTION B  
(Close up view)

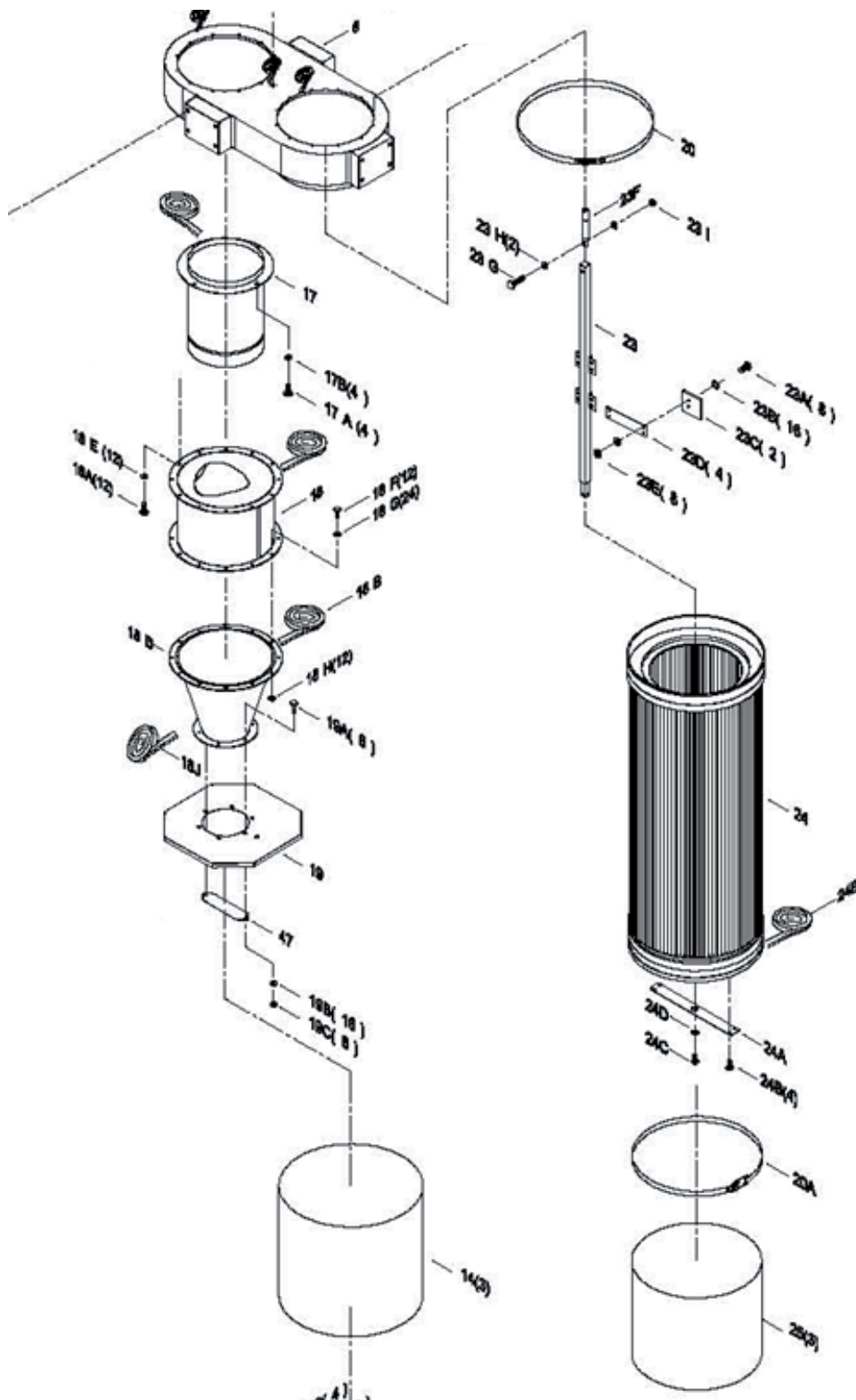



**9.3 SECTION C  
(Close up view)**

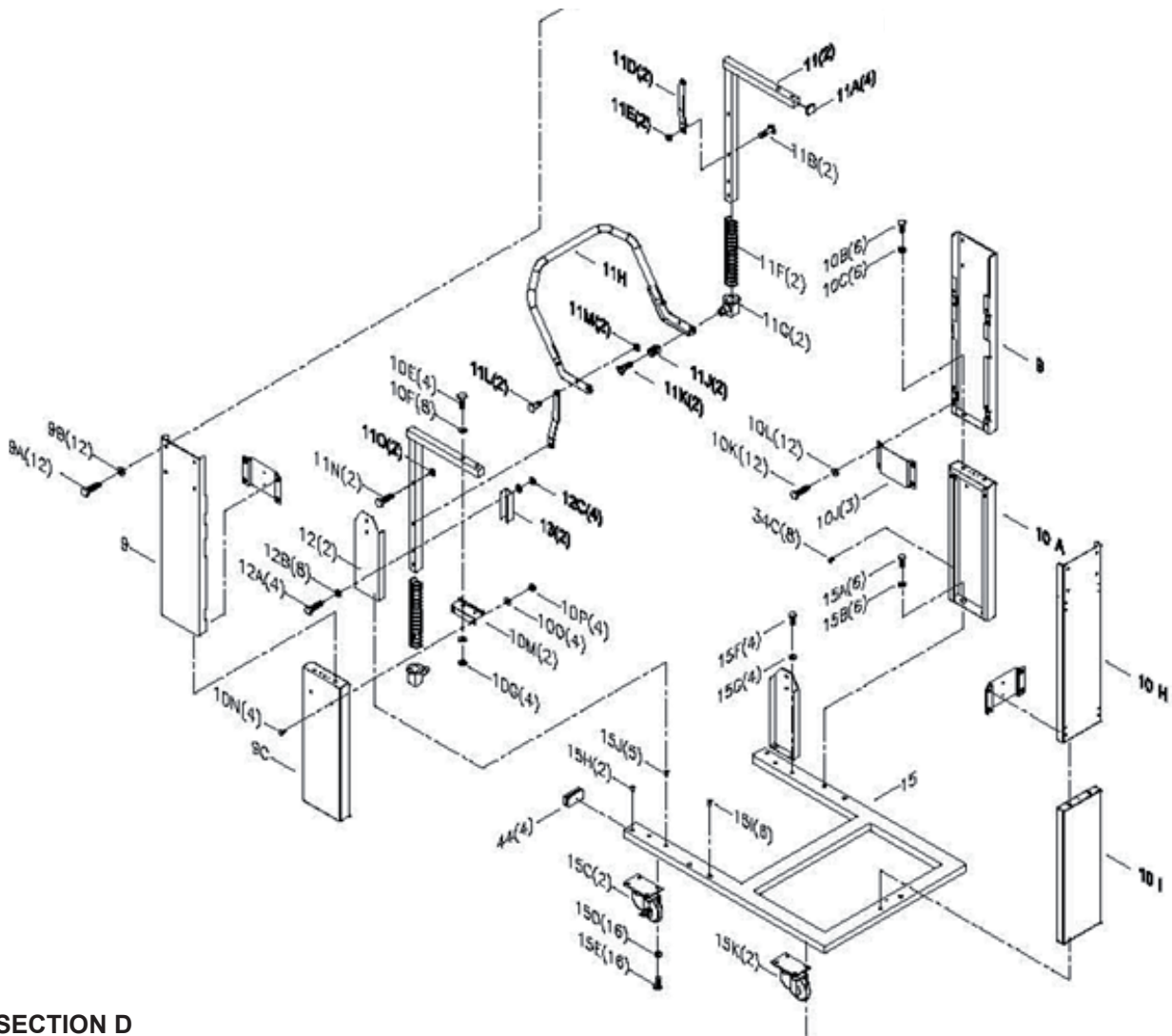

**9.4 SECTION D  
(Close up view)**

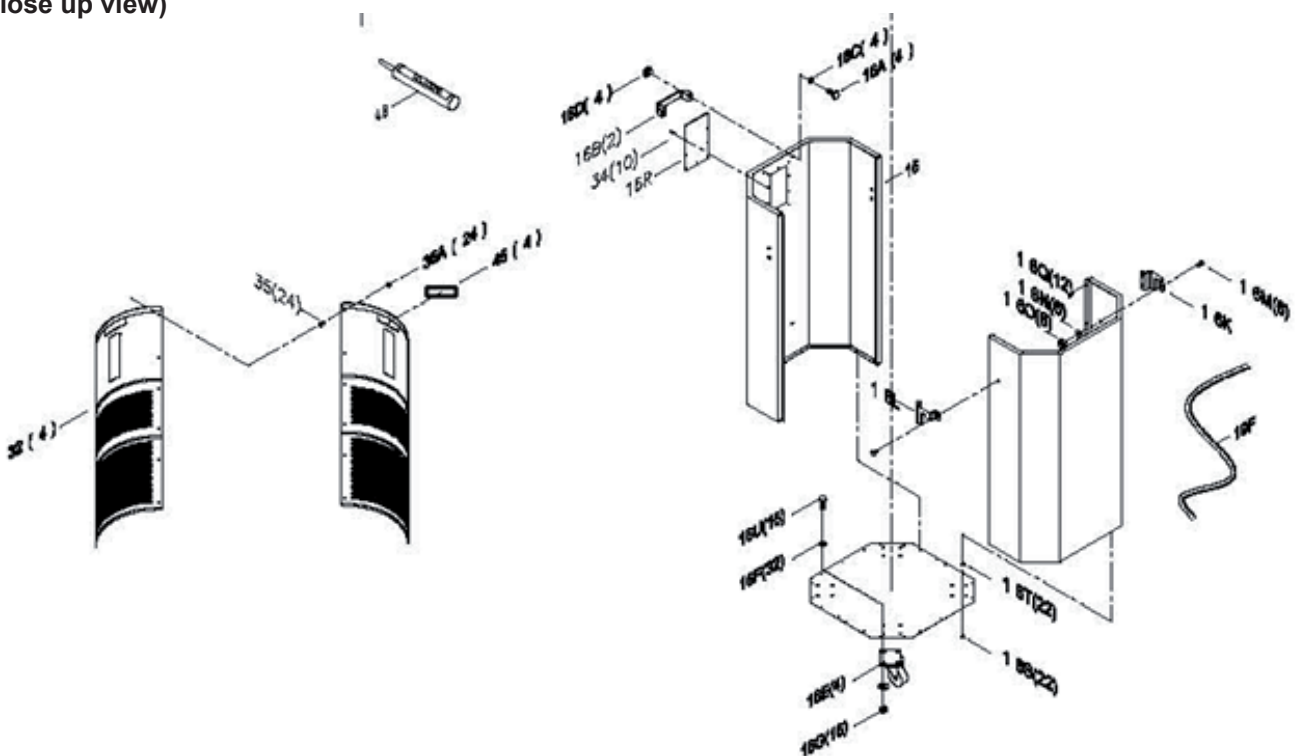

## 10. Parts list

Ref No	Part Number	Part Name & Description	QTY
1	PDCCF32201-1	MOTOR 3HP	1
1A	PDCCF32201-1A	MOTOR GASKET	1
2	PDCCF32201-2	MOTOR SUPPORT BASE	1
2A	PDCCF32201-2A	HEX LOCK BOLT 5/16" x 5/8"	12
2B	PDCCF32201-2B	FLAT WASHER 3/8"x23x2t"	8
2C	PDCCF32201-2C	HEX BOLT 3/8" x 1"	4
2D	PDCCF32201-2D	HEX NUT 3/8"	4
2E	PDCCF32201-2E	FLAT WASHER 3/8"x23x2mm	4
2F	PDCCF32201-2F	HEX BOLT 3/8" x 1-1/4"	4
2G	PDCCF32201-2G	SWITCH PLATE	1
2H	PDCCF32201-2H	HEX BOLT 1/4" x 3/4"	4
2I	PDCCF32201-2I	FLAT WASHER 1/4"x19x1mm	4
3	PDCCF32201-3	FAN 15.5"	1
3A	PDCCF32201-3A	FLAT WASHER 3/8"x45x3t	1
3B	PDCCF32201-3B	HEX BOLT 3/8" x 1"	1
6	PDCCF32201-6	DUST CHUTE	1
6A	PDCCF32201-6A	CANISTER COVER PLATE	1
6B	PDCCF32201-6B	SHEET METAL THREAD BOLT 3/16" x 1/2"	12
8	PDCCF32201-8	COVER PLATE	1
8A	PDCCF32201-8A	SHEET METAL THREAD BOLT M4x12mm	4
9	PDCCF32201-9V2	TOP UPRIGHT SUPPORT V2.2021	2
9A	PDCCF32201-9A	HEX BOLT 5/16" x 3/4"	12
9B	PDCCF32201-9A	FLAT WASHER 5/16"x18x2mm	12
9C	PDCCF32201-9CV2	LOWER UPRIGHT SUPPORT TWO DOT (3B)235 V2.2021	1
10A	PDCCF32201-10AV2	LOWER UPRIGHT SUPPORT THREE DOT (2B) 235 V2.2021	1
11M	PDCCF32201-11M	HEX LOCK NUT 3/8"	2
11N	PDCCF32201-11N	HEX BOLT 3/8" x 1-1/2"	2
11O	PDCCF32201-11O	HEX LOCK NUT 3/8"	2
12	PDCCF32201-12V2	TRIANGULAR SUPPORT PLATE V2.2021	2
12A	PDCCF32201-12A	HEX BOLT 5/16" x 1-3/4"	4
12B	PDCCF32201-12B	FLAT WASHER 5/16"x18x2mm	8
12C	PDCCF32201-12C	HEX NUT 5/16"	4
13	PDCCF32201-13	LOWER SUPPORT PLATE	2
14	PDCCF32201-14V2	PLASTIC BAG Ø610 x 1200mm	3
15	PDCCF32201-15	BASE	1
15A	PDCCF32201-15A	HEX BOLT 3/8" x 3/4"	6
15B	PDCCF32201-15B	FLAT WASHER 3/8" x 23 x 2mm	6
15C	PDCCF32201-15C	SWIVEL CASTER 4"	2
15D	PDCCF32201-15D	FLAT WASHER 5/16"x18x2mm	16
15E	PDCCF32201-15E	HEX BOLT 5/16" x 3/4"	16
15F	PDCCF32201-15F	HEX BOLT 5/16" x 3/4"	4
15G	PDCCF32201-15G	FLAT WASHER 5/16"x18x2mm	4
15H	PDCCF32201-15H	RIVET NUT 1/4"	2
15I	PDCCF32201-15I	RIVET NUT 3/8"	6
15J	PDCCF32201-15J	RIVET NUT 5/16"	5
15K	PDCCF32201-15K	SWIVEL CASTER W/BRAKES 4"	2
16	PDCCF32201-16V2	OCTAGON DRUM FRONT PANEL V2.2021	1
16A	PDCCF32201-16A	FLAT HEAD PHILIP BOLT 5/16"x3/4"	4
16B	PDCCF32201-16B	HANDLE	2
16C	PDCCF32201-16C	FLAT WASHER 5/16"x23x2mm	4
16D	PDCCF32201-16D	HEX NUT 5/16"	4
18J	PDCCF32201-18J	FOAM TAPE 3x15mm x 80CM	1
19	PDCCF32201-19V2	OCTAGON DRUM LID V2.2021	1
19A	PDCCF32201-19A	HEX BOLT 5/16" x 3/4"	6
19B	PDCCF32201-19B	FLAT WASHER 5/16"x18x2mm	12
19C	PDCCF32201-19C	HEX NUT 5/16"	6
19D	PDCCF32201-19D	PLUG MSP-16	1
19E	PDCCF32201-19E	NUT AGL-16	1
19F	PDCCF32201-19F	RUBBER GASKET 1650mm	1
20	PDCCF32201-20	BAND CLAMP Ø400mm	1
20A	PDCCF32201-20A	SPRING BAND CLAMP Ø400mm	1
22	PDCCF32201-22	ROTATION CRANK	1
22A	PDCCF32201-22A	HEX BOLT 5/16" x 3/4"	1
22B	PDCCF32201-22B	FLAT WASHER 5/16"x30x3mm	1
22C	PDCCF32201-22C	GEAR Ø20mm	1
22D	PDCCF32201-22D	HEX BOLT 1/4" x 3/4"	4
22E	PDCCF32201-22E	FLAT WASHER 1/4" x 19 x 2mm	4
22F	PDCCF32201-22F	BEARING	1
22G	PDCCF32201-22G	SEAL	1
23	PDCCF32201-23V2	ROTATION SHAFT V2.2021	1
23A	PDCCF32201-23A	HEX BOLT 1/4" x 5/8"	8
23B	PDCCF32201-23B	FLAT WASHER 1/4" x 13 x 1mm	16
23C	PDCCF32201-23C	PADDLE	2
23D	PDCCF32201-23D	PADDLE BRANCH	4
23E	PDCCF32201-23E	HEX LOCK NUT 1/4"	8

Ref No	Part Number	Part Name & Description	QTY
23F	PDCCF32201-23F	ROTATION SHAFT CONNECTION	1
23G	PDCCF32201-23G	HEX BOLT 5/16" x 1-1/2"	1
10B	PDCCF32201-10B	HEX BOLT 5/16" x 3/4"	6
10C	PDCCF32201-10C	FLAT WASHER 5/16"x18x2t	6
10E	PDCCF32201-10E	HEX BOLT 5/16" x 1-3/4"	4
10F	PDCCF32201-10F	FLAT WASHER 5/16"x18x2t	4
10G	PDCCF32201-10G	HEX NUT 5/16"	8
10H	PDCCF32201-10H	TOP UPRIGHT SUPPORT ONE DOT (1A)	1
10I	PDCCF32201-10IV2	LOWER UPRIGHT SUPPORT ONE DOT (1B) 235V2.2021	1
10J	PDCCF32201-10J	UPRIGHT SUPPORT REINFORCEMENT PLATE	3
10K	PDCCF32201-10K	HEX BOLT 5/16" x 3/4"	12
10L	PDCCF32201-10L	FLAT WASHER 5/16"x18x2mm	12
10M	PDCCF32201-10M	FOOT-PEDAL BAR SUPPORT	2
10N	PDCCF32201-10N	CARRIAGE BOLT 5/16"x1/2"	4
10O	PDCCF32201-10O	CARRIAGE BOLT 5/16"x18x2mm	4
10P	PDCCF32201-10P	HEX NUT 5/16"	4
11	PDCCF32201-11	FOOT PEDDLER BAR	2
11A	PDCCF32201-11A	PLUG 25, 25	4
11B	PDCCF32201-11B	HEX BOLT 3/8"	2
11D	PDCCF32201-11D	MOVEABLE SUPPORT BRACE	2
11E	PDCCF32201-11E	HEX LOCK NUT 3/8"	2
11F	PDCCF32201-11F	SPRING Ø42mm x 242mm	2
11G	PDCCF32201-11G	SKID BLOCK	2
11H	PDCCF32201-11H	OCTAGON DRUM FOOT- PEDAL	1
11J	PDCCF32201-11J	TOPPING Ø24mmx30mm	2
11K	PDCCF32201-11K	HEX BOLT M8 x 30mm	2
11L	PDCCF32201-11L	HEX BOLT 3/8"	2
16E	PDCCF32201-16E	DRUM CASTER 3"	4
16U	PDCCF32201-16U	HEX BOLT 5/16" x 3/4"	16
16F	PDCCF32201-16F	FLAT WASHER 5/16"x18x2mm	32
16G	PDCCF32201-16G	HEX NUT 5/16"	16
16H	PDCCF32201-16HV2	OCTAGON DRUM BACK PANEL V2.2021	1
16K	PDCCF32201-16K	LEFT SIDE PLATE	1
16L	PDCCF32201-16L	RIGHT SIDE PLATE	1
16M	PDCCF32201-16M	CARRIAGE BOLT 1/4" x 1/2"	6
16N	PDCCF32201-16N	FLAT WASHER 1/4"x19x2mm	6
16O	PDCCF32201-16O	HEX NUT 1/4"	6
16P	PDCCF32201-16PV2	OCTAGON DRUM BASE PANEL V2.2021	1
16R	PDCCF32201-16RV2	WINDOW V2.2021	1
16S	PDCCF32201-16SV2	M5 SHEET METAL SCREW	22
16T	PDCCF32201-16TV2	PLASTIC BOLT END CAP	22
16Q	PDCCF32201-16Q	THREAD BOLT M4 x 12mm	10
17	PDCCF32201-17	INTAKE CYLINDER	1
17A	PDCCF32201-17A	HEX BOLT 5/16" x 5/8"	4
17B	PDCCF32201-17B	FLAT WASHER 5/16"x18x2mm	4
18	PDCCF32201-18	CYCLONE BARREL	1
18A	PDCCF32201-18A	HEX BOLT 5/16" x 3/4"	12
18B	PDCCF32201-18B	FOAM TAPE 3 x 6mm x 10M	1
18D	PDCCF32201-18D	CYCLONE FUNNEL	1
18E	PDCCF32201-18E	FLAT WASHER 5/16"x18x2mm	12
18F	PDCCF32201-18F	HEX BOLT 5/16" x 3/4"	12
18G	PDCCF32201-18G	FLAT WASHER 5/16"x18x2mm	24
18H	PDCCF32201-18H	HEX NUT 5/16"	12
23H	PDCCF32201-23H	FLAT WASHER 5/16" x 18x 2mm	2
23I	PDCCF32201-23I	HEX LOCK NUT 5/16"	1
24	PDCCF32201-24	CANISTER FILTER Ø400mm x 900mm	1
24A	PDCCF32201-24A	ROTATION SHAFT BASE	1
24B	PDCCF32201-24B	SHEET METAL PHILIP BOLT 3/16" x 3/4"	4
24C	PDCCF32201-24C	HEX BOLT 5/16" x 3/4"	1
24D	PDCCF32201-24D	FLAT WASHER 5/16" x 23 x 2mm	1
24E	PDCCF32201-24E	FOAM TAPE 3 x 25mm x 1.5M	1
25	PDCCF32201-25	PLASTIC BAG Ø400mm x 600mm	3
27A	PDCCF32201-27A	SHEET METAL BOLT M4 x 12mm	3
27C	PDCCF32201-27C	INTAKE SPLITTER 8" x 4" X 3	1
32	PDCCF32201-32V2	DRUM INSERT V2.2021	4
33	PDCCF32201-33	FLAT HEAD BOLT M4 x 6mm	4
34	PDCCF32201-34	RIVET 3-2	10
34C	PDCCF32201-34C	RIVET NUT 1/4"	8
34D	PDCCF32201-34D	RIVET NUT 5/16"	18
35	PDCCF32201-35	ROUND HD BOLT 3/16" x 1/2"	24
35A	PDCCF32201-35A	NUT 3/16"	24
36	PDCCF32201-36V2	FREQUENCY REMOTE SWITCH V2.2021	1
44	PDCCF32201-44	RUBBER PLUG 30mm x 60mm	4
47	PDCCF32201-47	CROSSBAR	1
48	PDCCF32201-48	SILICONE	1



IGM nástroje a stroje s.r.o., Ke Kopanině 560,  
Tuchoměřice, 252 67, Czech Republic, E.U.  
+420 220 950 910, [www.igm.cz](http://www.igm.cz)